

LIFTRONIC Air Series

New

Latest generation industrial manipulators of the INDEVA family. They combine the strength of a traditional pneumatic manipulator with the intelligence of the INDEVA.

Their power for lifting is pneumatic, but they are electronically controlled.

They are suitable for handling offset and/or very heavy loads. Models are available from 80 to 250 kg, that can be supplied either column, ceiling or overhead rail mounted.

Compared to traditional pneumatically controlled manipulators, Liftronic Air offers important advantages which help improve **safety, ergonomics and productivity**.

LIFTRONIC Air vs. PNEUMATIC CONTROL MANIPULATOR

	INDEVA LIFTRONIC Air electronically controlled	TRADITIONAL PNEUMATIC control MANIPULATOR
Safety	total: thanks to the electronic control. Important anti-jumping function: in case of load drop the system counter balances the weight loss immediately, thus avoiding dangerous quick moves upwards	limited: only mechanical or pneumatic devices available. In case of load drop no blocking device is available, and the arm with gripping tool will move quickly upward, thus causing safety hazard
Auto weight sense and Load balancing	real and efficient: by means of an electronic load cell and electronic signalling, the INDEVA not only automatically balances the load weight, but it also senses the load weight continually, adjusting the balancing accordingly; moves and load positioning are therefore very precise and instant	The auto weight sense function is <i>not easy</i> to implement and is <i>not precise</i> . Usually, balancing is carried out manually by means of pressure regulator or push buttons; Counter balancing is much slower because it takes much longer for pneumatic signalling to travel around the circuits
Load balancing along the whole vertical stroke	constant: special sensors and electronic controls allow perfect balancing along the whole stroke	inconstant: due to the impossibility of cylinder pressure adjusting as the parallelogram position changes
Vertical movements	quick and precise: thanks to its special finger tip sensing handle the INDEVA reacts instantaneously to the operator's touch, thus providing fine control of up/down movements	slower and unprecise: due to typical air technological limitations, the system responsiveness is slow, thus causing unprecise movements
Load positioning	very precise: the INDEVA doesn't over-travel, nor bounce and doesn't require lots of little corrective movements to reach the required position; the load doesn't suffer any impact when positioned	not precise and awkward: it requires lots of little corrective movements to reach the required position. Load positioning implies an impact that can harm delicate loads
Use versatility	modifications to movements parameters are simple and quick via electronic software	modifications to tooling functions are difficult and result in costly interventions
Man / machine interface	simple and efficient: by means of display	complicated, costly and inefficient: by means of pneumatic lamps which are slow to react and not very reliable
Interface other machines	simple: thanks to electronic control	complicated and costly: by means of electric devices with further energy consumption
Electronic cycle counter	it can be associated to many different actions	only the total cycle counter is available (not resettable)
Diagnostic and maintainance	simple fault finding by means of microprocessor	fault finding, especially for complex systems, is very difficult



New



column mounted LIFTRONIC AIR

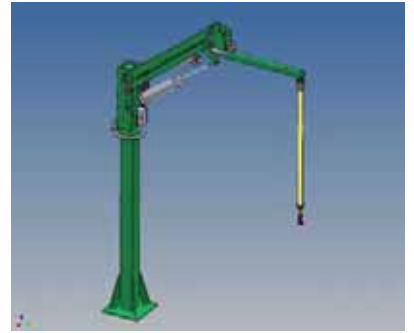

ceiling mounted LIFTRONIC AIR

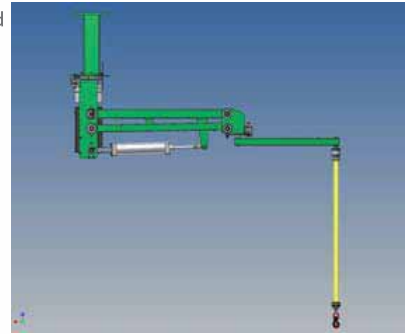

overhead rail mounted LIFTRONIC AIR

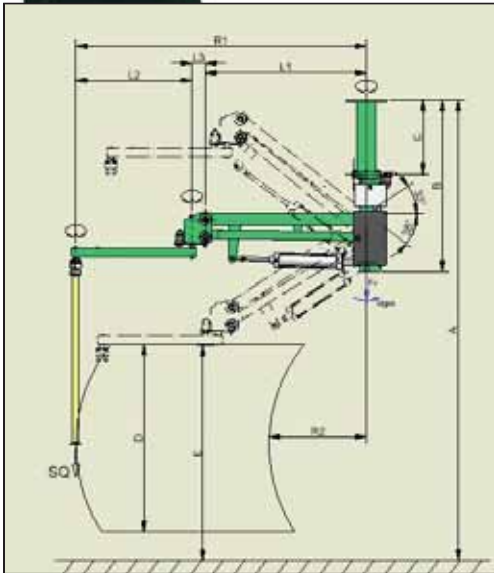
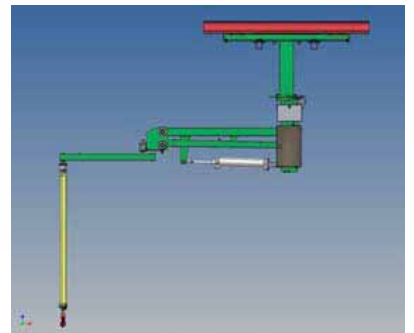

LIFTRONIC AIR Column mounted		LA80	LA160	LA250
Capacity	Kg	80	160	250
Vertical stroke	mm	1752	1716	1451
Arm length (R1)	mm	2700	2700	2605
Offset handling : max. distance from the lifting tool Z axis	mm	300	300	500
Uncovered area (R2)	mm	907	935	900
Rotation around column axis	degrees	360°		
Rotation around tool axis	degrees	standard: 550° optional: continuous		
Air pressure min.	Bar	6,5		

